

GE Energy

X\$D Ultra[®] 661

Heat Exchanger Motors

5-75 HP

460 Volt



imagination at work

a product of
ecomagination

Experience, Safety and Quality

We've manufactured motors for over 125 years.

In 1879, GE founder, Thomas Edison constructed the first electric motor ever made for a 110 to 120 Volt line at Menlo Park, NJ. This device still exists and is operative! It is located in the Edison Historical Collection in New Jersey.

We continue to innovate manufacturing.

Leading the way in six sigma and lean manufacturing processes helps to ensure that GE can deliver the best value in its product.

X\$D Ultra® 661 meets and exceeds user expectations.

Safety

- The X\$D Ultra® 661 incorporates four-point lifting lugs which are integrally cast into the motor frame. This allows the user to pick up the motor vertically using all four points instead of a single eyebolt.

Improved Customer Operating Performance

- The X\$D Ultra® 661 meets or exceeds API-661 and IEEE-841 Standards. It includes advanced features such as a superior insulation and bearing system and a performance test report for each motor—all backed by a five year warranty. The X\$D Ultra® 661 is one of the most durable and reliable motors you can buy.

Improved Customer Environmental Performance

- Replacing one 75 HP, 1800 RPM Pre-EPAAct motor (rewound once) with GE's X\$D Ultra® 661 could save enough energy to power two US households for more than one year.
- If a US Industrial user replaced one 75 HP, 1800 RPM Pre-EPAAct motor with an X\$D Ultra®, greenhouse gas emissions could be reduced by as much as 12 metric tons per year.

Built to the highest Standards and Certifications

- Rated for IP-55 protection.
- NEMA, UL, CSA, IEEE-45, IEEE-841, API-661.

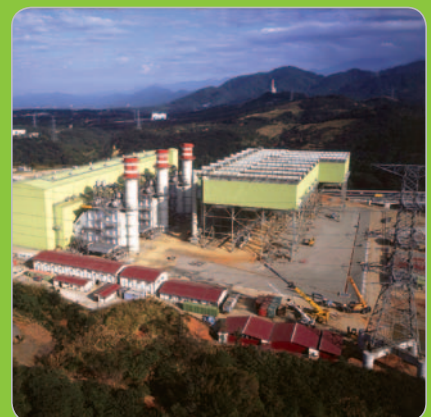

Powerful Features

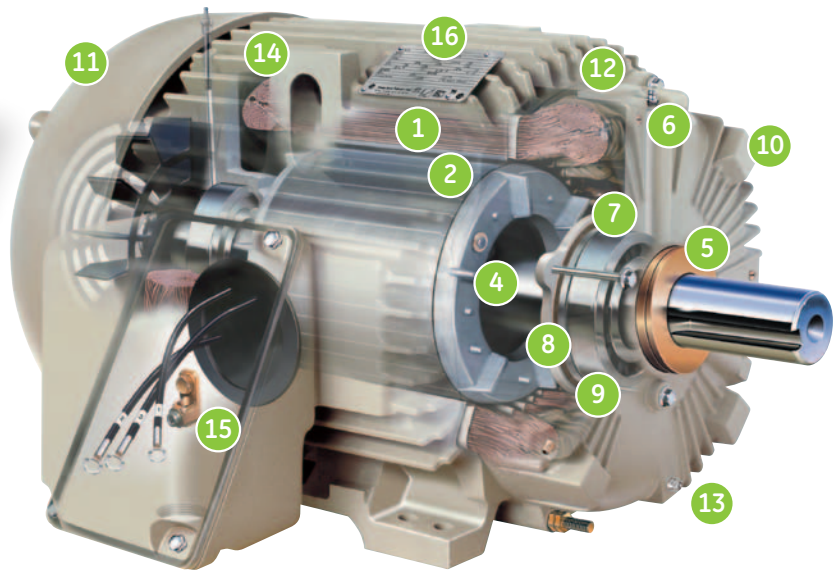

Superior Electrical Performance

The XSD Ultra® 661 meets or exceeds NEMA Premium® Nominal efficiencies and exceeds all NEMA Premium® minimum guaranteed efficiencies

- 1 GEGARD2400™ insulation systems feature Class H insulation materials and 1.15 service factor. This system increases motor protection against IGBT drive voltage spikes up to 2,400 volts @ 0.1 microsecond rise time, which exceeds NEMA MG1-31 standards. It is also capable of an Infinite:1 variable torque speed range.
- 2 Meets NEMA design B torque and current requirements.
- 3 A five-year warranty comes standard with every XSD Ultra® 661 motor. (60 months operational/66 months maximum from shipment).

Bearings

GE's bearing system assures the maximum possible bearing life when combined with a maintenance program.

- 4 Overall displacement is 0.0004 inches peak-to-peak. Rotor assembly balanced to ISO 1940 Grade 1.0. This helps to extend the life of the motor and the connected equipment.
- 5 A non-contact labyrinth seal is integrated to both the drive-end and opposite drive-end ensuring IP55 protection of the bearing system.
- 6 Fully charged lubrication system with a temperature-resistant polyurea grease suitable for a wide temperature range (-40°C to +130°C).
- 7 An oversized roller bearing has been designed to yield 40,000 hours minimum L10 bearing life for belted loads.
- 8 A cast-iron gasketed bearing inner cap is secured by a bolt with a copper washer to ensure a totally enclosed system. This helps to retain lubricant and protects the bearing system and interior of the motor from contaminants.
- 9 Low temperature rise designs (15% cooler on average than IEEE 841-2009 specification).

Proven Reliability

For years severe duty motors from GE have proven their performance and reliability in the most demanding process industry environments.

- 10 Cast-in vibration pads provide mounting locations for a minimum of three axial and three radial probes.
- 11 Rugged cast iron frame, conduit box, endshields and fan cover.
- 12 RTV sealed frame-to-endshield rabbit fit.
- 13 Stainless steel T-drain at the lowest point in bottom endshield and brass plug on upper endshield helps to relieve and prevent condensation.

Safety

GE has added features which make this product safe to install, operate and maintain.

- 14 Safer lifting is possible with a four-point, cast-in lifting system versus a single eyebolt.
- 15 A silicon bronze box lug ground terminal is located in the conduit box. An additional ground terminal post is located on the drive-end endshield for greater operational safety.
- 16 Maximum surface temperature of 200°C stamped on auxiliary nameplate. Qualified for Division 2 applications. Optional CSA certification for Division 2 applications is also available.

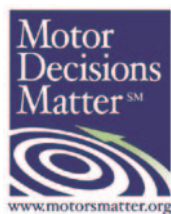

Selection Guide

Stocked as W8 (shaft up) and field-modifiable to W6 (shaft down) except where noted.

HP	RPM	Volts	Frame	FLA	Nom. Eff.	Guar. Min. Eff.	Cat. No.	Norm. Stk.	Wt. (lbs)	C Dim. (in)	Notes
5	1800	460	184T	6.6	89.5	88.5	M6621	N	101	15.90	117
7.5	1800	460	213T	9.1	91.7	91.0	M6622	N	200	20.10	
10	1800	460	215T	12.0	91.7	91.0	M6623	Y	220	20.10	
15	1800	460	254T	18.0	92.4	91.7	M6624	Y	315	25.60	
20	1800	460	256T	23.3	93.0	92.4	M6625	Y	350	25.60	
25	1800	460	284T	29.8	93.6	93.0	M6626	Y	460	28.58	
30	1800	460	286T	35.5	93.6	93.0	M6627	Y	510	28.58	
40	1800	460	324T	50.8	94.5	94.1	M6628	Y	710	32.04	
50	1800	460	326T	63.9	94.5	94.1	M6629	Y	740	32.04	
60	1800	460	364T	71.2	95.0	94.5	M6630	N	1020	34.89	118
60	1800	460	364T	71.2	95.0	94.5	M6631	N	1020	34.89	119
75	1800	460	365T	86.6	95.4	95.0	M6632	N	1090	34.89	118
75	1800	460	365T	86.6	95.4	95.0	M6633	N	1090	34.89	119

Drip Cover Kits

Cat. No.	Part No.	Frame	Norm. Stk.
A1201	294A4267AD-G01	140	Y
A1202	294A4267AD-G02	180	Y
A1203	294A4267AD-G03	210	Y
A1204	294A4267AD-G04	250	Y
A1205	294A4267AD-G05	280	Y
A1206	294A4267AD-G06	320	Y

Notes:

117 Ball Bearing

118 W6 (shaft down) is standard mount and not field modifiable to W8 (shaft up)

119 W8 (shaft up) is standard mount and not field modifiable to W6 (shaft down)

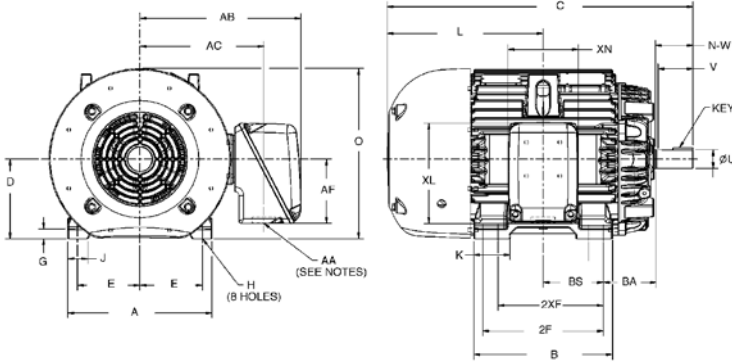

Conduit Box Dimensions

Frame	Nominal HP	Apprx. Vol.	Dimensions (Inches)						
			A4*	AB	AC	AF	XL	XN	
182-184	5	32	0.75	7.82	6.32	2.50	4.30	5.40	
213-215	10	55	1.00	9.50	7.42	3.50	5.78	4.15	
254-256	20	140	1.25	11.68	9.12	4.59	7.37	5.37	
284-286	30	140	1.50	12.44	9.88	4.59	7.37	5.37	
324-326	50	346	3.00	16.13	12.43	6.44	10.14	7.00	
364-365	75	346	3.00	17.07	13.37	6.44	10.14	7.00	

Weights and Dimensions

Frame	Apprx. Net Wt. (lbs)	Dimensions (Inches)																				
		Shaft					Mounting (18)															
		Width	Depth	Length	N-W	U (1)	V	E	H	BA	BS	2F	2XF	A	B	C	D (3)	G	J	K	L	O
184T	101	0.250	0.250	1.750	2.75	1.125	2.50	3.75	0.46	2.75	2.75	5.50	4.50	8.68	6.64	15.91	4.50	0.46	1.54	2.58	7.66	9.25
213T	200	0.312	0.312	2.380	3.38	1.375	3.12	4.25	0.46	3.50	3.50	7.00	5.50	9.60	8.00	20.15	5.25	0.57	1.47	3.12	9.77	10.43
215T	220	0.312	0.312	2.380	3.38	1.375	3.12	4.25	0.46	3.50	3.50	7.00	5.50	9.60	8.00	20.15	5.25	0.57	1.47	3.12	9.77	10.43
254T	315	0.375	0.375	2.380	4.00	1.625	3.76	5.00	0.58	4.25	5.00	10.00	8.25	11.20	11.30	25.29	6.25	0.65	1.52	3.93	12.34	12.50
256T	350	0.375	0.375	2.880	4.00	1.625	3.76	5.00	0.58	4.25	5.00	10.00	8.25	11.20	11.30	25.29	6.25	0.65	1.52	3.93	12.34	12.50
284T	460	0.500	0.500	3.250	4.62	1.875	4.38	5.50	0.58	4.76	5.50	11.00	9.50	12.40	12.80	28.58	7.00	0.76	1.75	4.12	13.70	13.88
286T	510	0.500	0.500	3.250	4.62	1.875	4.38	5.50	0.58	4.76	5.50	11.00	9.50	12.40	12.80	28.58	7.00	0.76	1.75	4.12	13.70	13.88
324T	685	0.500	0.500	3.880	5.25	2.125	5.00	6.25	0.67	5.25	6.00	12.00	10.50	14.40	13.80	32.04	8.00	0.99	2.01	3.62	15.54	17.07
326T	800	0.500	0.500	3.880	5.25	2.125	5.00	6.25	0.67	5.25	6.00	12.00	10.50	14.40	13.80	32.04	8.00	0.99	2.01	3.62	15.54	17.07
364T	1122	0.625	0.625	4.250	5.88	2.375	5.64	7.00	0.69	5.88	6.13	12.25	11.25	16.00	14.40	43.89	9.00	1.09	2.26	3.40	17.00	19.02
365T	1155	0.625	0.625	4.250	5.88	2.375	5.64	7.00	0.69	5.88	6.13	12.25	11.25	16.00	14.14	43.89	9.00	1.09	2.26	3.40	17.00	19.02

Typical 460 Volt Performance Data

HP	FL RPM	NP FLA	Design LRA	NEMA B LRA	Code KVA/HP	FLT (lb-ft)	LRT (lb-ft)	BDT (lb-ft)	NP Eff. Full Load	Guar. Eff. Full Load	75% Load Eff.	50% Load Eff.	NP PF Full Load	75% Load Power Factor	50% Load Power Factor	Max KVAR
5	1755	6.6	43.1	46.0	J	15.0	34.4	43.8	89.5	88.5	90.5	90.1	79.5	74.2	63.4	2.0
7.5	1770	9.1	62.8	63.5	H	22.3	42.6	62.9	91.7	91.0	92.2	91.6	84.5	81.1	72.5	2.3
10	1765	12.1	81.0	81.0	H	29.7	56.0	80.8	91.7	91.0	92.4	92.1	84.5	81.4	73.2	3.0
15	1770	18.0	108.4	116.0	G	44.5	96.4	111.3	92.4	91.7	93.1	93.0	84.5	81.1	72.4	4.3
20	1770	23.3	139.9	145.0	G	59.4	132.1	143.5	93.0	92.4	93.7	93.9	86.5	84.0	76.9	4.8
25	1775	29.6	164.9	182.5	G	73.9	134.4	165.5	93.6	93.0	94.2	94.0	84.5	81.5	73.2	6.9
30	1775	35.3	191.6	217.5	G	88.7	158.7	192.3	93.6	93.0	94.3	94.3	85.0	82.4	74.7	7.8
40	1780	49.5	271.7	290.0	G	117.8	201.3	265.5	94.5	94.1	94.7	94.2	80.0	74.1	63.8	14.6
50	1775	62.5	355.5	362.5	G	148.0	290.7	342.1	93.6	93.0	94.2	93.8	80.0	77.6	68.4	18.8
60	1785	69.5	416.7	435.0	G	176.5	275.0	448.7	95.0	94.5	95.7	95.3	85.0	80.5	71.9	16.9
75	1785	86.6	513.1	542.5	G	220.8	347.0	552.4	95.4	95.0	95.7	95.3	85.0	80.7	72.1	21.0

Notes:

- 1 Shaft diameters 1 1/2 inches and smaller will come within the limits of +0.000 inch, -0.0005 inch diameters 1 5/8 inches and larger +0.000 inch, -0.001 inch
- 3 Tolerance on "D" dimension for rigid base motors will be +0.000 inch, -0.060 inch. No tolerance has been est. for the "D" dimension of resilient mounted motors.
- 18 Motor feet have dual mounting holes per foot allowing NEMA F-1 or F-2 assembly while maintaining critical NEMA mounting dimensions. Also hole positions are the same in paired frame sizes (i.e. 284-286).
- 20 324 frame motors have mounting holes for the 324 frame size only.

* Providing mounting conditions permit, conduit box may be turned so that entrance can be made upward, downward, or from either side. Weights shown are approximate shipping weights and should be used for estimating only.

GE Energy
 Fort Wayne, IN 46802
 800 541 7191
 www.gemotors.com

For more information, please contact your GE sales representative.

GE, ecomagination, X\$D Ultra®, GEGARD2400™ and Six Star Bearing System™ are trademarks and a service mark of General Electric Company.

NEMA Premium® is a trademark of NEMA.

©2011, General Electric Company. All rights reserved.

GEA18868 (06/2011)

